



BROWN EUROPE

RX TORSIONALLY FLEXIBLE COUPLING

RX Flexible Couplings are ideal for transmitting torque and damping the torsional vibrations produced in machinery. These couplings are available in aluminium, cast iron (GG25), SG iron (GGG40) and steel. The running quality and durability are improved by all over machining and are able to transmit high torques with low centrifugal mass and small overall dimensions.



RX-GS Backlash Free Flexible Couplings are manufactured in high strength aluminium for sizes up to 38/45 or steel from size 42. The hubs are accurately machined to achieve precise dimensional characteristics and the polyurethane elastic element is designed to give zero backlash.

RX-GS (design 6.0) Backlash Free Flexible Coupling is ideal for applications requiring precision and/or high rotational speeds. The absence of keys or grub screws makes this coupling very well balanced and greatly facilitates installation and removal. The absence of keyways also avoids fretting corrosion and backlash between shaft and hub.



BROWN EUROPE

Revenge Road,
Lordswood Ind. Estate, Chatham,
Kent.
ME5 8UD.
Tel. (0044) 1634 687141
Fax. (0044) 1634 686347
Email. Mail@Brownroupltd.com



RX TORSIONALLY FLEXIBLE COUPLING

The factors shown below must be taken into consideration for the selection of a RX coupling when checking the rated torque shown in the rating tables.

f_b = Shock Factor

f_s = Start Factor

f_t = Temperature Factor

$$T_{KN} \geq T_N \times f_b \times f_s \times f_t$$

T_{KN} = Nominal torque of coupling

T_N = Actual torque of the drive

SHOCK FACTOR f_b

	f _b
Uniform operation and low masses to be accelerated Hydraulic-gear pumps, vane-cell pumps	1.0
Uniform operation and medium masses to be accelerated Axial piston pumps, Radial piston pumps, Machine tools, Textile-machinery, Mixing machines, Agitators for liquids, Blowers, Plate-bending machines, Wood working machines, Grinding machines, screw-type compressors	1.2
Non-uniform operation and medium masses to be accelerated Conveyors, Generators, Agitators, Freight elevators, Winches, Willowing machines	1.3
Non-uniform operation and medium masses to be accelerated and moderate shocks Tube mills, Cement mills, Ball mills, Centrifugal mills, Centrifuges, Looms, Washers, Kneaders, Threshers, Concrete mixers, Chain conveyors, Lifts	1.4
Non-uniform operation and large masses to be accelerated and heavy shocks Punches, Hammer mills, Piston pumps, Presses, Jolters, Forging presses, Wood grinders, Wire drawing machines, Rubber rollers	1.6
Non-uniform operation and very large masses to be accelerated and extremely heavy shocks Heavy table rollers, Stone crushers, Rolling mill for metals, Brick presses	1.8

START FACTOR f_s

Starts per hour	100	200	400	800
f _s	1	1.2	1.4	1.6

TEMPERATURE FACTOR f_t

Ambient temperature	-30°C +30°C	+40°C	+60°C	+80°C
f _t	1.0	1.2	1.4	1.8

EXAMPLE OF CALCULATION:

Details of driver side

AC Motor	Size 315 M
Motor output	P = 132 kW
Motor speed	n = 1485 rpm
Starts per hour	25
Ambient temperature	+ 60°C

Details of driven side

Screw -type compressor	P = 120 kW
Compressor speed	n = 1485 rpm

COUPLING SELECTION

Calculation of drive torque

$$T_N = 9550 \cdot \frac{120 \text{ kW}}{1485 \text{ rpm}} = 771.7 \text{ Nm}$$

$$T_{KN} = T_N \times f_b \times f_s \times f_t$$

$$T_{KN} = 771.7 \times 1.2 \times 1 \times 1.4 = 1296 \text{ Nm}$$

Selected: **RX 90**

Spider: **92 Shore A**

Data of the catalogue: **T_{KN} = 2400 Nm**
T_{KMAX} = 4800 Nm



RX TORSIONALLY FLEXIBLE COUPLING

RATINGS

		STANDARD SPIDER (Nm)			ALTERNATIVE SPIDER ELEMENTS (Nm)									
RX SIZE		WHITE/YELLOW - 92° Shore			RED - 98° Shore			GREEN 64 Shore D-F ##			Max Speed rpm		Torsion angle	
Standard Hub	Large Hub	Nominal torque Tk N	Max torque Tk MAX	Reversing torque Tk W	Nominal torque Tk N	Max torque Tk MAX	Reversing torque Tk W	Nominal torque Tk N	Max torque Tk MAX	Reversing torque Tk W	30 m/s* 40 m/s*		Nom Torque	Max Torque
19	19/24	10	20	2.6	17	34	4.4	21	42	5.5	14000	19000		
24	24/30	35	70	9	60	120	16	75	150	19.5	10600	14000		
28	28/38	95	190	25	160	320	42	200	400	52	8500	11800		
38	38/45	190	380	49	325	650	85	405	810	105	7100	9500		
42	42/55	265	530	69	450	900	120	560	1120	145	6000	8000		
48	48/60	310	620	81	525	1050	137	655	1310	170	5600	7100		
55	55/70	375	750	93	625	1250	163	825	1650	215	4750	6300	3.2°	5°
65	65/75	425	850	111	650	1300	169	1175	2350	305	4250	5600		
75	75/90	975	1950	254	1500	3000	390	2410	4820	625	3550	4750		
90	90/100	2400	4800	624	3600	7200	963	4500	9000	1170	2800	3750		
100	100/110	3300	6600	858	4950	9900	1287	-	-	-	2500	3350		
110	110/125	4800	9600	1248	-	-	-	-	-	-	2240	3000		
125	125/145	6000	12000	1560	-	-	-	-	-	-	2000	2650		

*Peripheral speeds of over $v = 30$ m/s are only possible in couplings manufactured from steel or spheroidal graphite. Dynamic balancing is required.
Hub material should be GGG40 or Steel.

Note :- Unless clearly requested in your order we shall supply spiders in 92° Shore A.
When selecting couplings the duty factor for the drive and driven machine must be taken into account.

RX SPIDER IDENTIFICATION

Spider Type	Identification Colour	Material	Admissible Temperature (°C)		Available From Stock RX Size	RANGE OF APPLICATION
			Continuous	Short Time		

STANDARD SPIDERS

92 Sh A	White/Yellow	Polyurethane	-40 to +90	-50 to +120	19 to 125	General drives of all ranges of machinery and hydraulics for standard applications with medium elasticity
95/98 Sh A	Red	Polyurethane	-30 to +90	-40 to +120	19 to 100	General drives with higher loads for small twisting angles applications with poor elasticity
64 Sh D-F	Green	Polyurethane	-30 to +110	-30 to +130	19 to 90	Diesel Engine drives - For high air moisture Hydrolysis resistance -For misalignment of critical speed

SPIDERS FOR SPECIAL APPLICATIONS

94 Sh A-T	Orange	Polyurethane	-50 to +110	-60 to +130	19 to 90	Diesel Engine drives -For high dynamic load For high air moisture - Hydrolysis resistance
-----------	--------	--------------	-------------	-------------	----------	--

ORDERING DATA

RX 42	GG25	92° shore	1	42	50	1a	50	50
Size of coupling	Material	Spider Hardness	Hub Design	Finish Bore H7	Hub length	Hub Design	Finish Bore H7	Hub length



RX TORSIONALLY FLEXIBLE COUPLING

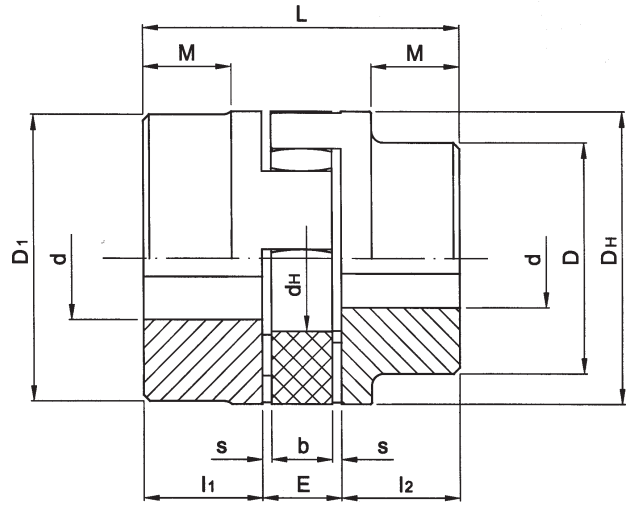
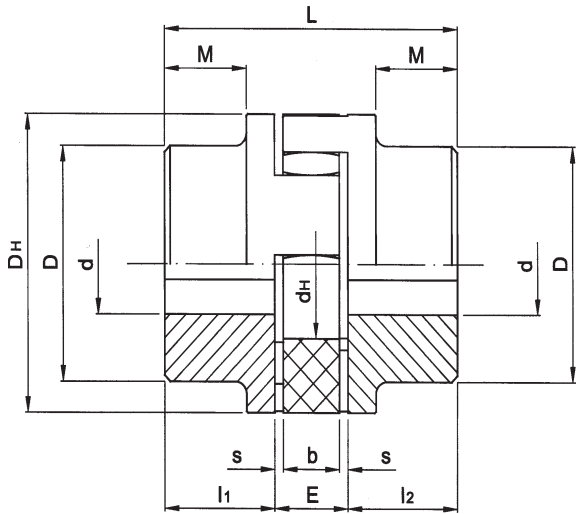

SIZE	Type of Hub	Design	CAST ALUMINIUM			STEEL/CAST IRON*			Dimensions							
			Pilot Bore d	Min Max d	D	Pilot Bore d	Min Max d	D D1	l1 & l2	E	s	b	L	M	DH	dH
19	standard hub	1	6	6-19	31	-	-	-	25	16	2	12	66	20	40	18
19/24	large hub	1a	18	20-24	38	-	6-24	40	25	16	2	12	66	20	40	18
19/24	large long hub	1b	-	-	-	-	6-24	40	40	16	2	12	96	-	40	18
24	standard hub	1	6	8-24	39	-	-	-	30	18	2	14	78	24	55	27
24/30	large hub	1a	22	25-30	48	-	8-32	55	30	18	2	14	78	-	55	27
24/30	long large hub	1b	-	-	-	-	8-32	55	50	18	2	14	118	-	55	27
28	standard hub	1	9	10-28	46	-	-	-	35	20	2.5	15	90	28	65	30
28/38	large hub	1a	26	30-38	61	-	10-38	65	35	20	2.5	15	90	-	65	30
28/38	long large hub	1b	-	-	-	-	10-38	65	80	20	2.5	15	180	-	65	30
38	standard hub	1	12	14-38	64	-	14-38	66	45	24	3	18	114	37	80	38
38/45	large hub	1a	36	40-45	75	-	40-45	78	45	24	3	18	114	37	80	38
38/45	long large hub	1b	-	-	-	-	40-45	78	70	24	3	18	164	62	80	38
42	standard hub	1	-	-	-	-	16-42	75	50	26	3	20	126	40	95	46
42/55	large hub	1a	-	-	-	-	45-55	93	50	26	3	20	126	40	95	46
42/55	long large hub	1b	-	-	-	-	45-55	93	75	26	3	20	176	65	95	46
48	standard hub	1	-	-	-	-	50-60	85	56	28	3.5	21	140	45	105	51
48/60	large hub	1a	-	-	-	-	50-60	103	56	28	3.5	21	140	45	105	51
48/60	long large hub	1b	-	-	-	-	50-60	103	80	28	3.5	21	188	69	105	51
55	standard hub	1	-	-	-	-	22-55	98	65	30	4	22	65	52	120	60
55/70	large hub	1a	-	-	-	53	60-70	118	65	30	4	22	65	52	120	60
55/70	long large hub	1b	-	-	-	53	60-70	118	90	30	4	22	210	77	120	60
65	standard hub	1	-	-	-	-	25-65	115	75	35	4.5	26	185	61	135	68
65/75	large hub	1a	-	-	-	63	70-75	133	75	35	4.5	26	185	61	135	68
65/75	long large hub	1b	-	-	-	63	70-75	133	100	35	4.5	26	235	86	135	68
75	standard hub	1	-	-	-	-	30-75	135	85	40	5	30	210	69	160	80
75/90	large hub	1a	-	-	-	73	80-90	158	85	40	5	30	210	69	160	80
75/90	long large hub	1b	-	-	-	73	80-90	158	110	40	5	30	260	104	160	80
90/100	large hub	1a	-	-	-	-	45-100	170	100	45	5.5	34	245	81	200	100
			STEEL			CAST IRON (GG25)										
100/110	large hub	1b	-	45-110	180	-	-	-	110	50	6	38	270	89	225	113
110/125	large hub	1b	-	60-125	200	-	60-125	200	120	55	6.5	42	295	96	255	127
125/145	large hub	1b	-	60-145	230	-	60-145	230	140	60	7	46	340	112	290	147

Steel hubs and spheroidal graphite (GGG40) hubs available on request.

*Either material may be supplied unless by special request



RX-GS BACKLASH FREE COUPLINGS

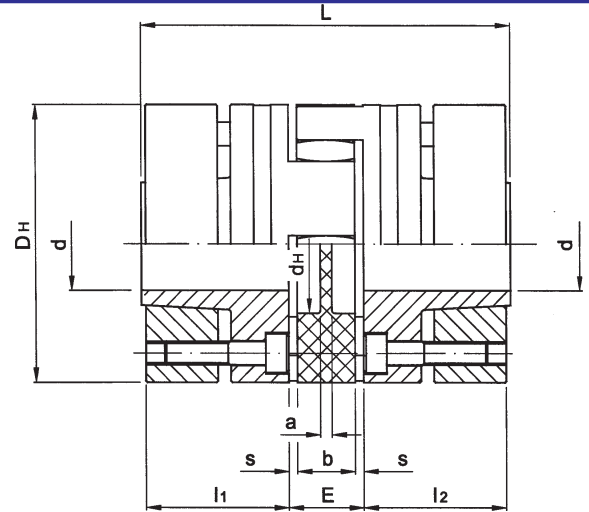
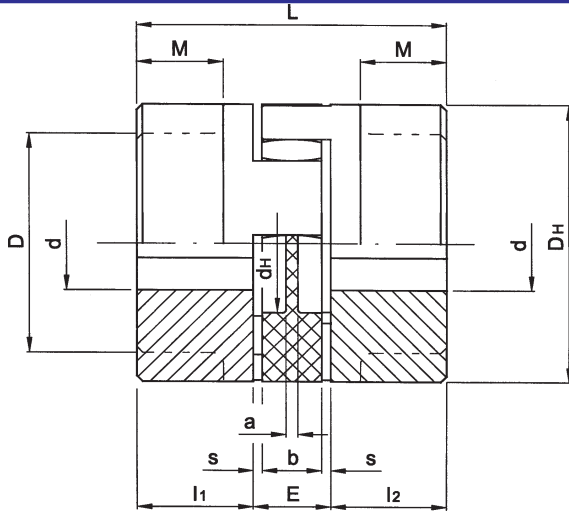

Size	Finish Bore min/max	ALUMINIUM HUBS Dimensions (mm)										Grubscrew		Clamping Bolt			
		D	D _H	d _H	L	l ₁ /l ₂	M	E	b	s	a	G	t	M ₁	t ₁	DiaD _K	T _A (Nm)
9	4-9	-	20	7.2	30	10	-	10	8	1.0	1.5	M4	5	M2.5	5	23.4	0.76
14	6-14	-	30	10.5	35	11	-	13	10	1.5	2	M4	5	M3	5	32.2	1.34
19/24	6-24	-	40	18	66	25	-	16	12	2.0	3	M5	10	M6	12	45.7	10.5
24/28	8-28	-	55	27	78	30	-	18	14	2.0	3	M5	10	M6	14	56.4	10.5
28/38	10-38	-	65	30	90	35	-	20	15	2.5	4	M6	15	M8	15	72.6	25
38/45	12-45	-	80	38	114	45	-	24	18	3.0	4	M8	15	M8	20	83.3	25
		STEEL HUBS															
42	14-55	85	95	46	126	50	28	26	20	3.0	4	M8	20	M8	20	78.8	25
48	15-62	95	105	51	140	56	32	28	21	3.5	4	M8	20	M10	22	90.6	69
55	20-70	120	120	60	160	65	-	30	22	4	5	M10	22	M10			69
65	25-75	135	135	68	185	75	-	35	26	4.5	5	M10	22	M			120X

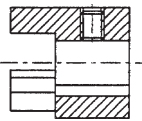

Hub design 1.0 - Bore and keyway with grub screw fixing

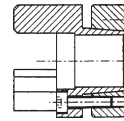

Hub design 6.0 - Clamp ring design (no keyway)

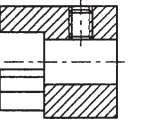

Hub design 1.1 - Bore with grub screw fixing (no keyway)

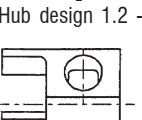

Hub design 1.2 - Bore only (no keyway or grub screw)

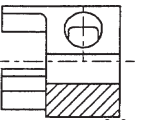

Hub design 2.0 - Clamp hub without keyway (size RXGS 9 - RXGS 19)

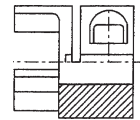

Hub design 2.5 - Clamp hub without keyway (RXGS24 - RXGS65)

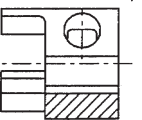

Hub design 2.1 - Clamp hub with keyway (RXGS9 - RXGS19)

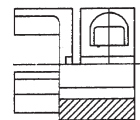

Hub design 2.6 - Clamp hub with keyway (RXGS24 - RXGS65)



RX TORSIONALLY FLEXIBLE COUPLING

METRIC BORES (H7)

Size	Hub	Cylindrical finish bores (mm) H7 keyway to DIN 6885 sheet 1 (JS9) and setscrew																																			
		6	8	9	10	11	12	14	15	16	18	19	20	22	24	25	28	30	32	35	38	40	42	45	48	50	55	60	65	70	75	80	85	90			
19	ALU 1				●	●	●	●	●	●		●																									
	ALU 1a												●		●																						
	GG25 1a									●	●	●	●	●	●	●																					
24	ALU 1			●	●	●	●	●	●	●		●		●	●																						
	ALU 1a															●	●																				
	GG25 1a									●	●	●	●	●	●	●	●	●	●	●	●	●	●	●	●	●	●	●	●	●	●	●	●	●	●	●	●
28	ALU 1									●	●	●	●	●	●	●	●	●	●	●	●	●	●	●	●	●	●	●	●	●	●	●	●	●	●	●	
	ALU 1a																	●	●	●	●	●	●	●	●	●	●	●	●	●	●	●	●	●	●	●	
	GG25 1a									●	●	●	●	●	●	●	●	●	●	●	●	●	●	●	●	●	●	●	●	●	●	●	●	●	●	●	●
38	ALU 1														●	●	●	●	●	●	●	●	●	●	●	●	●	●	●	●	●	●	●	●	●		
	ALU 1a																									●	●	●	●	●	●	●	●	●	●	●	
	GG25 1																																				
	GG25 1a																																				
42	GG25 1															●	●	●	●	●	●	●	●	●	●	●	●	●	●	●	●	●	●	●	●	●	
	GG25 1a																																				
48	GG25 1															●	●	●	●	●	●	●	●	●	●	●	●	●	●	●	●	●	●	●	●	●	
	GG25 1a																																				
55	GG25 1																																				
	GG25 1a																																				
65	GG25 1																																				
	GG25 1a																																				
75	GG25 1																																				
	GG25 1a																																				
90	GG25 1a																																				



RX TORSIONALLY FLEXIBLE COUPLING

MIS-ALIGNMENTS

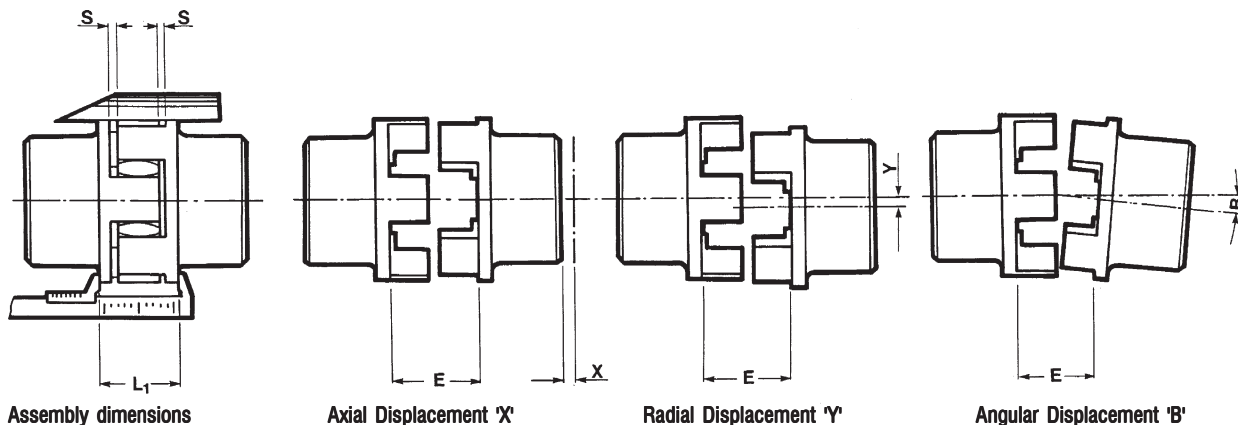

RX COUPLING SIZE	19 19/24	24 24/28	28 28/38	38 38/45	42 42/55	48 48/60	55 55/70	65 65/75	75 75/90	90/100	100 110/110	110 110/125	125 125/145
Distance E	16	18	20	24	26	28	30	35	40	45	50	55	60
Distance S	2	2	2.5	3	3	3.5	4	4.5	5	5.5	6	6.5	7
Distance L1	26	30	34	40	46	50	56	63	72	83	92	103	116
Max. axial displacement X	1.2	1.4	1.5	1.8	2.0	2.1	2.2	2.6	3.0	3.4	3.8	4.2	4.6
Max. radial displacement Y*	0.20	0.22	0.25	0.28	0.32	0.36	0.38	0.42	0.48	0.50	0.52	0.55	0.60
Max. angular displacement B		0.9*		1.0*		1.1*		1.2*				1.3*	

*1500 rpm

In addition to transmitting power without torsional vibrations RX couplings offer the advantage of coping with the frequently unavoidable axial, angular or radial shaft displacements thus preventing damage.

GRUBSCREW SIZES AND POSITIONS

With standard hubs and large hubs of RX 19 Alu - 48 Alu, threads for set screws are drilled opposite to the keyway. For all other sizes in cast iron (GG), nodular iron (GGG) and steel, the set screw thread is positioned through the keyway.

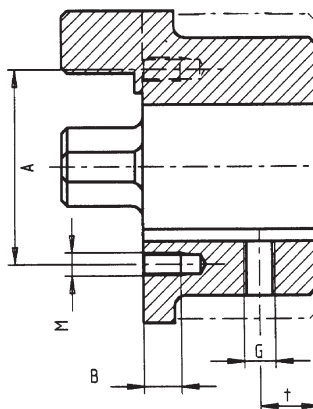

Threads for Shaft fixing

RX COUPLING SIZE	19 19/24	24 24/30	28 28/38	38 38/45	42 42/55	48 48/60	55 55/70	65 65/75	75 75/90	90/100	100/110	110/125	125/145
Grubscrew	M5	M5	M6	M8	M8	M8	M10	M10	M10	M12	M12	M16	M16
Distance t	10	10	15	15	20	20	20	20	25	30	30	35	40

Threads for Extractors (only supplied on request)

RX COUPLING SIZE	19 19/24	24 24/30	28 28/38	38 38/45	42 42/55	48 48/60	55 55/70	65 65/75	75 75/90	90/100	100/110	110/125	125/145
Tapped Holes 'M' on A Dia.	25	32	38	50	55	68	80	90	98	115	130	145	165
Extractor Thread M	M4	M4	M6	M6	M8	M10	M10	M12	M12	M16	M16	M16	M20



RX TORSIONALLY FLEXIBLE COUPLING

RX couplings for standard IEC Metric AC Motors

This table pre-supposes normal operation and the selections are made using a 92° shore (yellow) spider.

AC Motor Size	Motor Output 3000 rpm		RX Size	Safety factor with Tk MAX	Motor Output 1500 rpm		RX Size	Safety factor with Tk MAX	Motor Output 1000 rpm		RX Size	Safety factor with Tk MAX	Motor Output 750 rpm		RX Size	Safety factor with Tk MAX	Motor Shaft	
	kW	Nm			kW	Nm			kW	Nm			kW	Nm			kW	Nm
56	0.09	0.32	9	19	0.06	0.43	9	14	0.037	0.43	9	14					9 x 20	
	0.12	0.41		14	0.09	0.64		9.4	0.045	0.52		12	21					11 x 23
63	0.18	0.62	14	24	0.12	0.88	14	17	0.06	0.72	14	14					14 x 30	
	0.25	0.86		17	0.18	1.3		11.5	0.09	1.1		7.5	0.09	1.4			14	11
71	0.37	1.3	19/24	12	0.25	1.8	19/24	8.3	0.18	2.0	19/24	5.1	0.18	2.5	19/24	8.3		24 x 50
	0.55	1.9		7.9	0.37	2.5		6.0	0.25	2.7		5.6	0.12	1.8		8.0	19 x 40	
80	0.75	2.5	24/28	8.0	0.55	3.7	24/28	5.4	0.37	3.9	24/28	5.1	0.37	5.3	24/28	5.7	28 x 60	
	1.1	3.7		5.4	0.75	5.1		3.9	0.55	5.8		3.4	0.25	3.5		3.8	24 x 50	
90 S	1.5	5.0	28/38	4.0	1.1	7.5	28/38	2.7	0.75	8.0	28/38	2.5	0.37	5.3	28/38	2.5	28 x 60	
	2.2	7.4		2.7	1.5	10		2.0	1.1	12		5.8	0.55	7.9		6.4	38 x 80	
100 L	3	9.8	38/45	7.1	2.2	15	38/45	4.7	1.5	15	38/45	4.7	1.1	16	38/45	4.4	38 x 80	
	4	13		5.4	4	27		3.5	2.2	22		3.2	1.5	21		3.3	28 x 60	
112 M	5.5	18	42/55	10.6	5.5	36	42/55	2.6	3	30	42/55	6.3	2.2	30	42/55	6.6	38 x 80	
	7.5	25		7.6	7.5	49		3.9	4	40		4.8	3	40		4.8	42 x 110	
132 S			48/60				48/60				48/60				48/60		42 x 110	
																		48 x 110
132 M			48/60				48/60				48/60				48/60		55 x 110	
																		60 x 140
160 M	11	36	48/60	10.6	11	72	48/60	5.3	7.5	74	48/60	5.1	4	54	48/60	7.0	42 x 110	
	15	49		7.8	15	98		3.9	11	108		3.5	5.5	74		3.8	48 x 110	
160 L	18.5	60	48/60	6.3	15	121	48/60	4.4			48/60				48/60		55 x 110	
	22	71		7.5	18.5	144		3.7	15	148		3.6	11	145		3.7	55 x 110	
180 M	30	97	48/60	5.5	30	196	48/60	2.7	18.5	181	48/60	2.9	15	198	48/60	2.7	55 x 110	
	37	120		4.4	37	240		2.6	22	215		2.5	18.5	244		2.5	55 x 110	
200 L			48/60				48/60				48/60				48/60		55 x 110	
																		55 x 110
225 S			48/60				48/60				48/60				48/60		55 x 110	
																		55 x 110
225 M	45	145	48/60	3.7	45	292	48/60	2.1	30	293	48/60	2.1	22	290	48/60	2.1	55 x 110	
																		55 x 110

RX couplings for standard IEC metric AC Motors (except Brook)

250 M	55	177	48/50	3.5	55	356	55/70	2.3	37	361	55/70	2.3	30	392	65	3.1	60 x 140	65 x 140
280 S	75	241		3.4	75	484		2.6	45	438		2.9	37	483		2.6		
280 M	90	289	55 X 70	2.8	90	581	65/75	2.2	55	535	65/75	2.3	45	587	65/75	2.1	65 X 140	75 X 140
315 S	110	363		2.3	110	707		2.8	75	727		2.7	55	712		2.7		
315 M	132	423	65	3.0	132	849	75/90	2.3	90	873	75/90	2.3	75	971	75/90	4.9	65 X 140	80 X 170
				2.4	160	1030		4.7	110	1070		4.5	90	1170		4.1		
315 L	160	513	75	3.0	200	1290	90	3.7	132	1280	90	3.8	110	1420	90/100	3.4	75 X 140	95 X 170
	200	641		3.0	250	1600		3.0	160	1550		3.1	132	1710		2.8		
355 M	250	801	90	2.4	250	2020	90/100	2.4	200	1930	100	2.5	160	2070	100	3.2	75 X 140	95 X 170
				4.8	315	2020		2.4	250	2410		2.7	200	2580		2.6		
355 L	315	1010	100	4.2	355	2280	100	2.9	315	3040	110	2.6	250	3220	110	2.5	#	#
400 L#	400	1280		3.8	400	2560		2.6										

RX couplings for Brook AC Motors

Shaft sizes may vary

250 S	55	177	48/60	3.5	55	356	55/70	2.3	37	361	55/70	2.2	30	392	65/75	3.1	60 x 140	70 x 140
	75	241		2.5	75	484		4.0	45	438		4.4	37	483		4.0		
250 M	90	289	55/70	2.8	90	581	75/90	3.3	55	535	75/90	3.6	45	587	75/90	3.3	65 x 140	80 x 170
280 S	110	353		2.3	110	707		2.7	75	727		2.6	55	712		2.7		
315 S	132	423	65	2.9	132	849	90	2.3	90	873	90	2.2	75	971	90	2.0	65 x 140	85 x 170
				4.0	150	975		2.0	110	1070		4.4	90	117.0		4.1		
315 M	150	480	75	3.3	185	1200	90	4.0	132	1280	90	3.7	110	1420	90	3.3	75 x 140	100 x 210
	185	593		3.0	200	1300		3.7	150	1455		3.2	132	1717		2.7		
315 L	200	641	90	2.7	225	1462	90/100	3.2			90/100	2.6	150	1950	90/100	2.4	75 x 140	100 x 210
	225	721		2.4	250	1624		2.9	185	1795		2.4	150	1950		2.4		
355 S	250	801	90	2.1	280	1820	100	2.6	200	1941	100	2.2	185	2407	100	2.0	75 x 140	100 x 210
	280	897		4.7	315	2046		2.3	225	2183		2.2	185	2407		2.0		
355 M	315	1009	100	4.2	355	2306	100	2.0	250	2426	100	1.9	200	2602	100	2.5	75 x 140	100 x 210
	355	1137		4.0	375	2436		1.9	280	2717		2.4	200	2602		2.5		
355 L	375	1210	100	3.7	400	2598	100	2.5	315	3507	100	1.8	225	2927	100	2.2	75 x 140	100 x 210
	400	1281																